

## 26GHz Radar Level Meter

### Product Manual

Model: **SIRD50X SERIES**



**STACK INDUSTRY**

276/1, G.I.D.C, MAKARPURA, VADODARA-390010  
Mo.:9722165300 Email: [stack.industry@outlook.com](mailto:stack.industry@outlook.com)

## Directory

1、 Product Overview.....	1
2、 Product Introduction.....	2
3、 The Installation Requirements.....	4
4、 The Electrical Connection.....	6
5、 Instrument Commissioning.....	9
6、 Structure Size.....	11
7、 Technical Parameters.....	13
8、 Meter Linearity.....	14
9、 Product Model Selection.....	17

## 26GHz Radar Level Meter

### 1. Product Overview

This series of radar level meter adopted 26G high frequency radar sensor, the maximum measurement range can reach up to 80 meters. Antenna is optimized further processing, the new fast microprocessors have higher speed and efficiency can be done signal analysis, the instrumentation can be used for reactor, solid silo and very complex measurement environment.

#### ● Principle

Radar level transmitter antenna microwave pulse is narrow, the downward transmission antenna. Microwave exposure to the medium surface is reflected back again by the antenna system receives, sends the signal to the electronic circuit automatically converted into level signals (because the microwave propagation speed, electromagnetic wave to reach the target and the reflected back to the receiver this time is almost instantaneous).

- A Range set
- B Low adjustment
- C High
- D Blind area

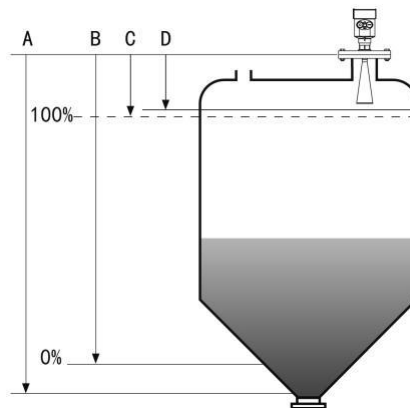

**Datum measurement:** Screw thread bottom or the sealing surface of the flange.

**Note:** Make sure the radar level meter the highest level cannot enter the measuring blind area (Figure D shown below).

#### ● The characteristics of 26G radar level meter:

- Small antenna size, easy to install; Non-contact radar, no wear, no pollution.
- Almost no corrosion, bubble effect; almost not affected by water vapor in the atmosphere, the temperature and pressure changes.
- Serious dust environment on the high level meter work has little effect.
- A shorter wavelength, the reflection of solid surface inclination is better.
- Beam angle is small, the energy is concentrated, can enhance the ability of echo and to avoid interference.
- The measuring range is smaller, for a measurement will yield good results.
- High signal-to-noise ratio, the level fluctuation state can obtain better performance.
- High frequency, measurement of solid and low dielectric constant of the best choice.

## 2. Product Introduction

### SIRD501



Application: All kinds of corrosive liquid  
Measuring Range: 10 meters  
Process Connection: Thread, Flange  
Process Temperature:  $-40^{\circ}\text{C}\sim 130^{\circ}\text{C}$   
Process Pressure:  $-0.1\sim 0.3\text{ MPa}$   
Accuracy:  $\pm 5\text{ mm}$   
Protection Grade: IP67  
Frequency Range: 26GHz  
Supply: 2-wire (DC24V) / 4-wire (DC24V / AC220V)  
Signal Output: 4... 20mA / HART (2-wire / 4-wire)  
RS485/ Modbus  
Outer Covering: Aluminum / Plastic / Stainless steel  
Explosion-proof Grade: Exia II C T6 Ga/ Exd II C T6 Gb

### SIRD502



Application: Slightly corrosive liquid  
Measuring Range: 30 meters  
Process Connection: Thread, Flange  
Process Temperature:  $-40^{\circ}\text{C}\sim 130^{\circ}\text{C}$  (Standard type)  
 $-40^{\circ}\text{C}\sim 230^{\circ}\text{C}$  (High temperature type)  
Process Pressure:  $-0.1 \sim 4.0\text{ MPa}$   
Accuracy:  $\pm 3\text{ mm}$   
Protection Grade: IP67  
Frequency Range: 26GHz  
Supply: 2-wire (DC24V) / 4-wire (DC24V / AC220V)  
Signal Output: 4... 20mA / HART (2-wire / 4-wire)  
RS485/ Modbus  
Outer Covering: Aluminum / Plastic / Stainless steel  
Explosion-proof Grade: Exia II C T6 Ga/ Exd II C T6 Gb

### SIRD503T



Application: Corrosive liquids, vapors, volatile liquids  
Measuring Range: 20 meters  
Process Connection: Flange  
Process Temperature:  $-40^{\circ}\text{C}\sim 130^{\circ}\text{C}$  (Standard type)  
 $-40^{\circ}\text{C}\sim 230^{\circ}\text{C}$  (High temperature type)  
Process Pressure:  $-0.1\sim 2.0\text{ MPa}$   
Protection Grade: IP67  
Accuracy:  $\pm 3\text{ mm}$   
Frequency Range: 26GHz  
Supply: 2-wire (DC24V) / 4-wire (DC24V / AC220V )  
Signal Output: 4... 20mA / HART (2-wire / 4-wire)  
RS485/ Modbus  
Outer Covering: Aluminum / Plastic / Stainless steel  
Explosion-proof Grade: Exia II C T6 Ga/ Exd II C T6 Gb

## SIRD503



Application: Solid material, Strong dust  
easy to crystallize, condensation occasion  
Measuring Range: 70 meters  
Process Connection: Universal Flange  
Process Temperature: -40°C~130°C(Standard type)  
-40°C~230°C(High temperature type)  
Process Pressure: -0.1~4.0 MPa (Flat flange)  
-0.1~0.3MPa (Universal flange)  
Protection Grade: IP67  
Accuracy: ±15mm  
Frequency Range: 26GHz  
Supply: 2-wire (DC24V) / 4-wire (DC24V /AC220V)  
Signal Output: 4... 20mA /HART (2-wire / 4-wire)  
RS485/ Modbus  
Outer Covering: Aluminum / Plastic / Stainless steel  
Explosion-proof Grade: Exia II C T6 Ga/ Exd II C T6 Gb

## SIRD504



Application: Solid material, Strong dust,  
easy to crystallize, condensation occasion  
Measuring Range: 80 meters  
Process Connection: Thread, Universal Flange  
Process Temperature: -40°C~130°C(Standard type)  
-40°C~230°C(High temperature type)  
Process Pressure: -0.1 ~ 0.3 MPa  
Measurement Accuracy: ±15mm  
Protection Grade: IP67  
Frequency Range: 26GHz  
Supply: 2-wire (DC24V) / 4-wire (DC24V /AC220V)  
Signal Output: 4... 20mA / HART (2-wire / 4-wire )  
RS485/ Modbus  
Outer Covering: Aluminum / Plastic / Stainless steel  
Explosion-proof Grade: Exia II C T6 Ga /Exd II C T6 Gb

## SIRD505



Application: Solid particles, Powder  
Measuring Range: 30 meters  
Process Connection: Thread, Flange  
Process Temperature: -40°C~130°C(Standard type)  
-40°C~230°C(High temperature type)  
Process Pressure: -0.1 ~ 4.0 MPa (Flat flange)  
-0.1 ~ 0.3 MPa (Universal Flange)  
Accuracy: ±15mm  
Protection Grade: IP67  
Frequency Range: 26GHz  
Supply: 2-wire (DC24V) / 4-wire (DC24V /AC220V)  
Signal Output: 4... 20mA /HART (2-wire / 4-wire )  
RS485/ Modbus  
Outer Covering: Aluminum / Plastic / Stainless steel  
Explosion-proof Grade: Exia II C T6 Ga /Exd II C T6 Gb

## SIRD506



Application: Hygienic liquid storage,  
Corrosive container

Measuring Range: 20 meters

Process Connection: Flange

Medium Temperature:  $-40^{\circ}\text{C}\sim 100^{\circ}\text{C}$

Process Pressure:  $-0.1\sim 1.6\text{ MPa}$

Accuracy:  $\pm 3\text{mm}$

Protection Grade: IP67

Frequency Range: 26GHz

Supply: 2-wire (DC24V) / 4-wire (DC24V / AC220V)

Signal Output: 4... 20mA/HART (2-wire / 4-wire )

RS485/ Modbus

Outer Covering: Aluminum / Plastic / Stainless steel

Explosion-proof Grade: Exia IIC T6 Ga /Exd IIC T6 Gb

### 3. The Installation Requirements

- **Installation guide:**

Be installed in the diameter of the 1/4 or 1/6.

Note: The minimum distance from the tank wall should be 200mm.

Note: ① datum

②The container center or axis of symmetry

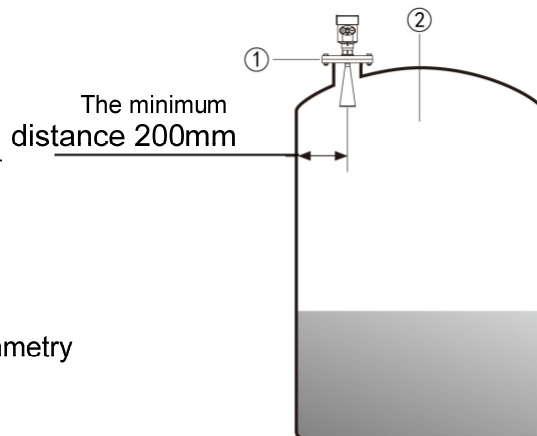

- The top conical tank level, can be installed at the top of the tank is intermediate, can guarantee the measurement to the conical bottom.

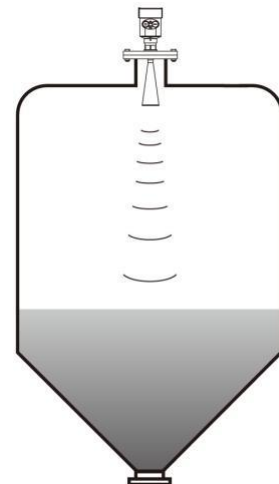

- A feed antenna to the vertical alignment surface.  
If the surface is rough, stack angle must be used to adjust the angle of universal flange of the antenna to the alignment surface.

(Due to the solid surface tilt will cause the echo attenuation, even Loss of signal.)

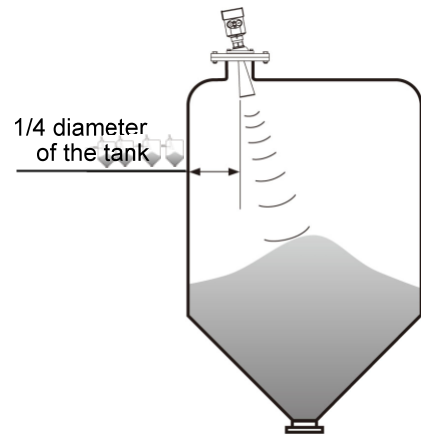

- **Typical installation errors:**

- Conical tank cannot be installed above the feed port.

**Note:** outdoor installation should adopt sunshade.

- ① Correct
- ② Error rainproof measures

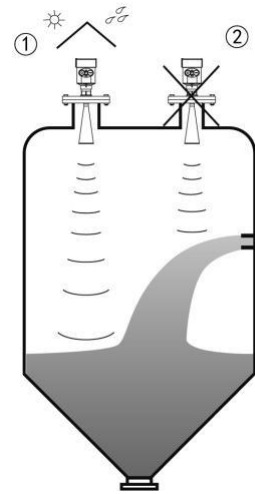

- The instrument cannot be installed in the arched or domed roof intermediate. In addition to produce indirect echo is also affected by the echoes. Multiple echo can be larger than the real value of signal echo, because through the top can concentrate multiple echo. So cannot be installed in a central location.

- ① Correct
- ② Error

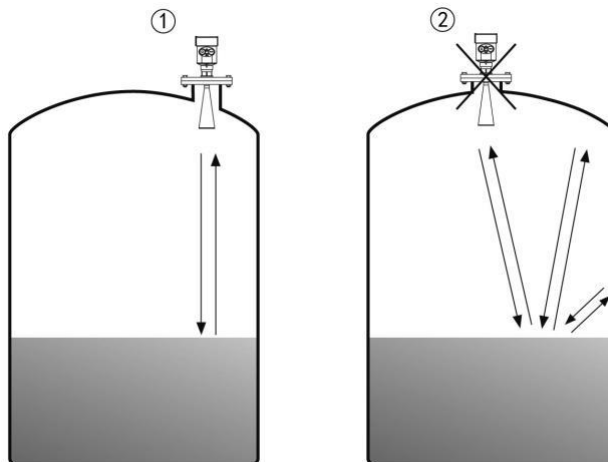

- There are obstacles affecting measurement needed reflection plate.

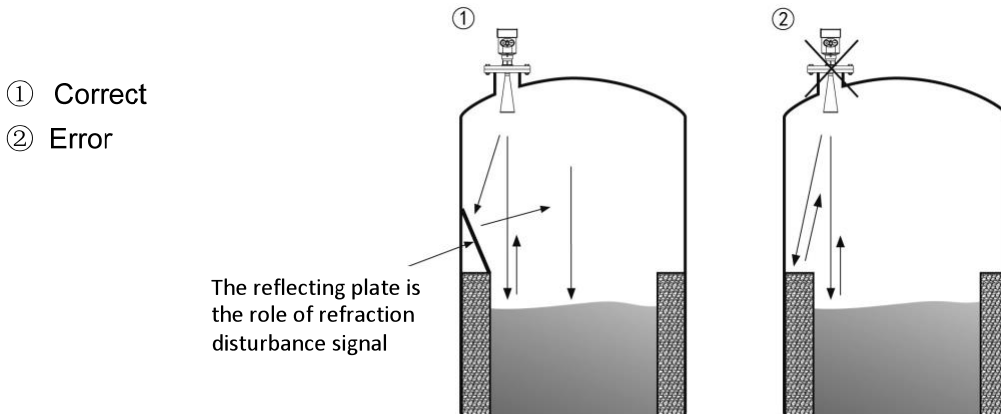

- **Height of nozzle:**

Antenna extends into the tank at least 10mm distance.

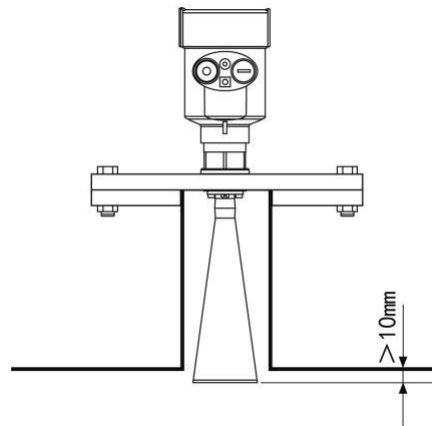

## 4. The Electrical Connection

- **The power supply voltage:**

---

(4~20)mA/HART (Two wire system) The power supply and the output current signal sharing a two core shield cable. The supply voltage range see technical data. For intrinsically safe type must be a safety barrier between the power supply and the instrument.

---



---

(4~20)mA/HART(Four wire system) Separate power supply and the current signal, respectively using a two-core shielded cable. The supply voltage range see technical data.

---



---

RS485 / Modbus Power supply and Modbus signal line separated respectively using a two-core shielded cable, the power supply voltage range see technical data.

---



- **Connection mode:**

- 24V two wire wiring diagram as follows:

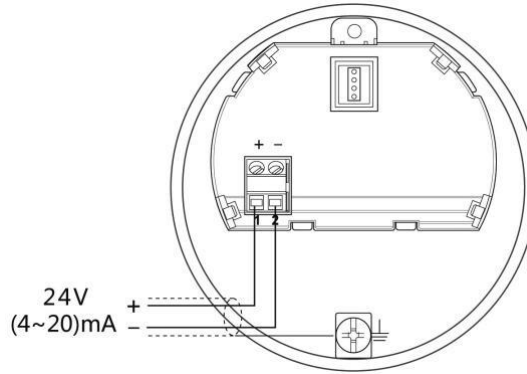

- 6~24V RS485/Modbus wiring diagram as follows:

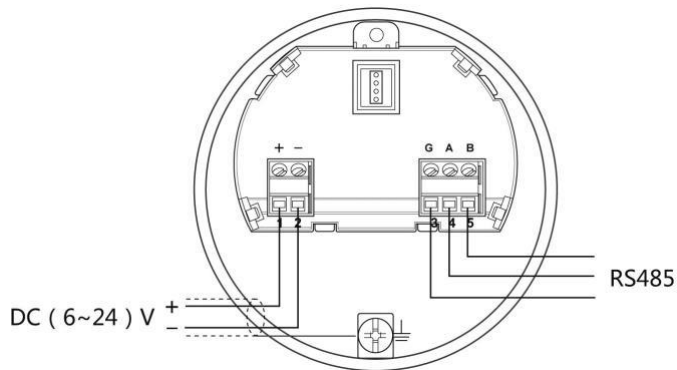

- **Explosion Proof Connection**

The intrinsic safety version sensors (Exia IIc T6) use Alu-die casting housing and filling Silicone rubber sealants internal structure aimed to prevent sparks resulted from circuit failure from leaking out. It is applicable for the continuous level measurement of flammable medium under Exia IIc T6.

A safety barrier FBS-2 must be used together with the intrinsic safety instrument. It is an associated device to this product for the power supply of this product. The main specification is intrinsic safety: Exia IIC, voltage of power supply: 24V DC±5%, short-circuit current: 135mA, operating current: 4...20mA.

All cables must be shielded. The max length is 500m for the cable from the barrier to the sensor. Stray capacitor≤0.1μF/Km, stray inductance 1mH/Km. Instrument must be connected to the ground potential. Any unapproved associated device is not allowed to be used.

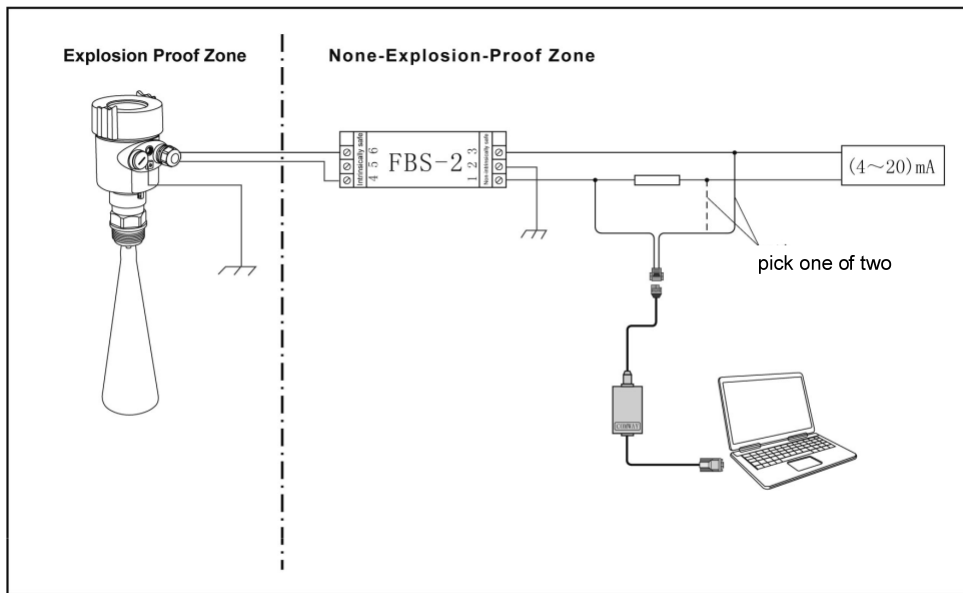

Adjustment with Software

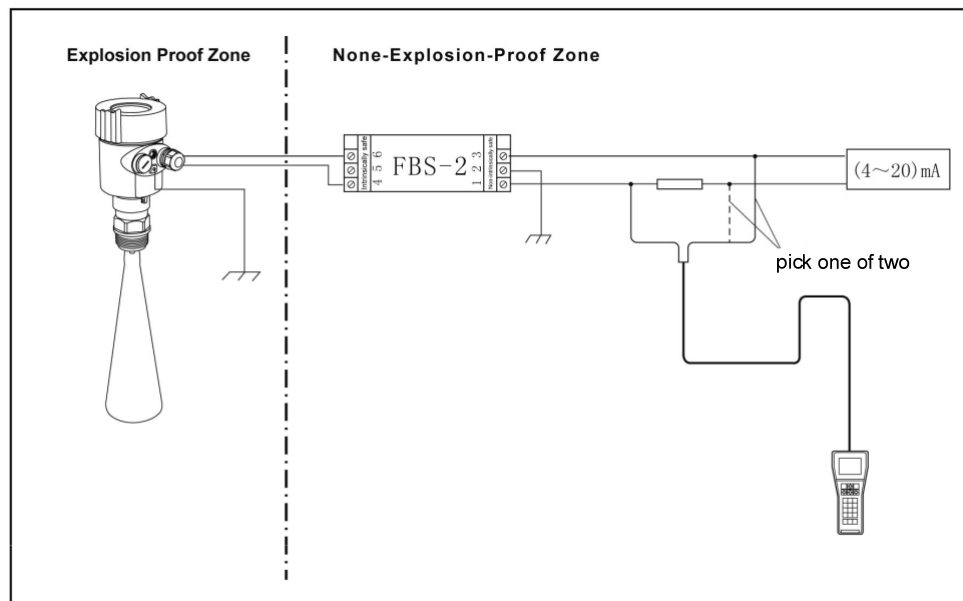

Adjustment with HART Handheld Programmer

● **Safety instructions:**

- Please observe the local electrical code requirements!
- Please comply with local requirements for personnel health and safety regulations. All electrical components of instrument operation must be completed by the formal training of professionals.
- Please check the instrument nameplate to provide product specifications meet your requirements. Please make sure that the power supply voltage and instrument nameplate on the requirements.

- **Protection grade:**

This instrument meets the protection class IP66/67 requirements, please ensure the waterproof cable sealing head. The following diagram:

:

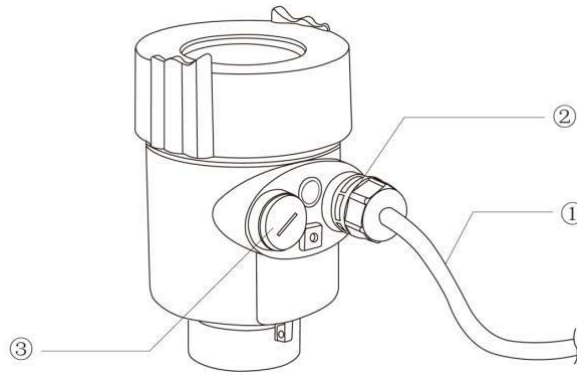

### **How to install to meet the requirements of IP67:**

Please make sure that the sealing head is not damaged.

Please make sure that the cable is not damaged.

Please make sure that the cable for use with electrical connection specification.

Cable into the electrical interface before its curved downward, ensure that the water will not flow into the shell, see the ①

Tighten the cable seal head, see the ②

Please electrical interface will not use blind plug tight, see the ③

## **5. Instrument Commissioning**

- **There are three kinds of debugging method:**

- 1) Display / Keyboard
- 2) Host debugging
- 3) HART handheld programmer

- **Display / Keyboard:**

Please debug the instrumentation by four buttons on the display screen. There are three debug menu languages optional. After debugging is generally used only for display, through the glass window can read measured value very clearly.

Display / Keyboard

① Liquid crystal display(LCD)

② The key

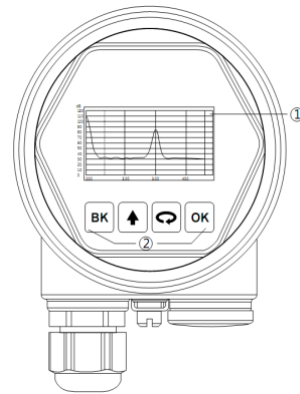

● **PC debugging:**

Connected to PC by HART

① RS232 interface or USB interface

② Radar level meter

③ HART adapter

④ 250 Ω resistor

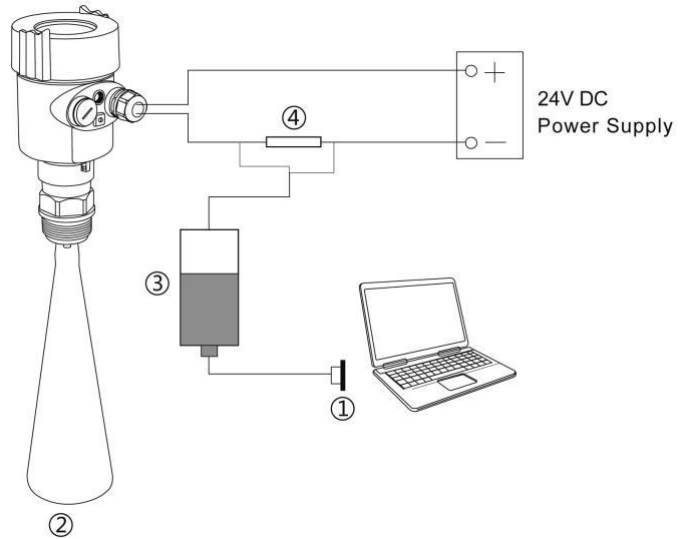

● **HART handheld programmer:**

① HART handheld programmer

② Radar level meter

③ 250 Ω resistor

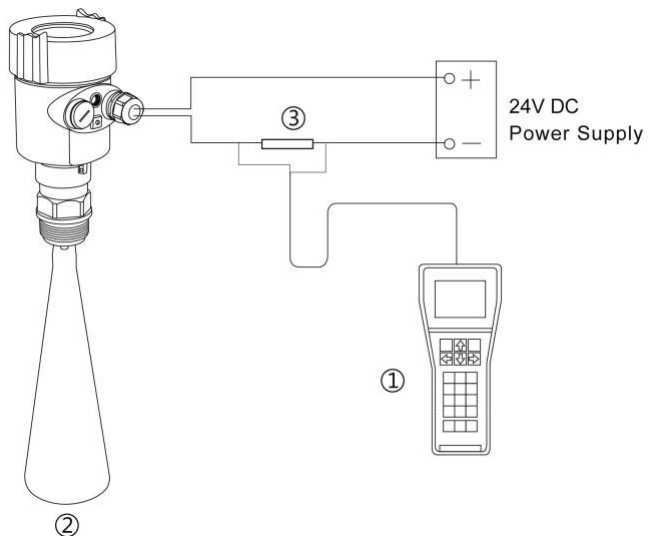

## 6. Structure Size (Unit: mm)

- The outer shell:

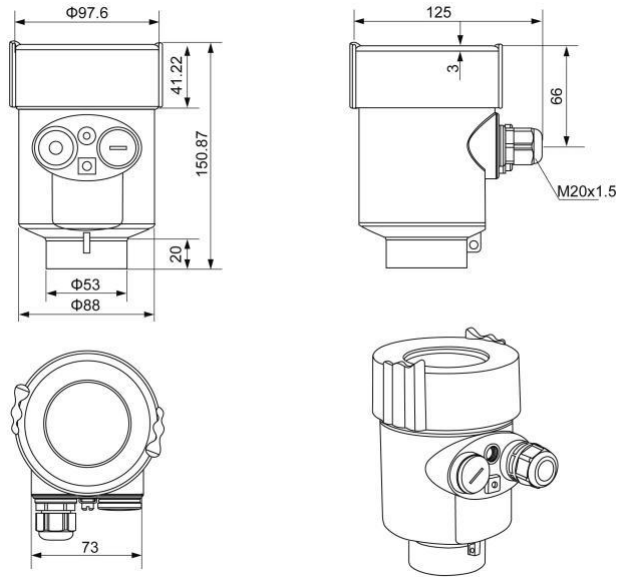

- Appearance size:  
SIRD501

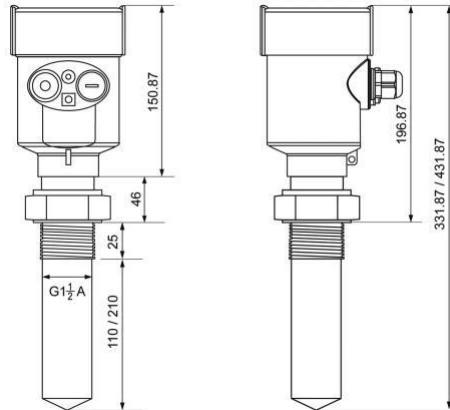

## SIRD502

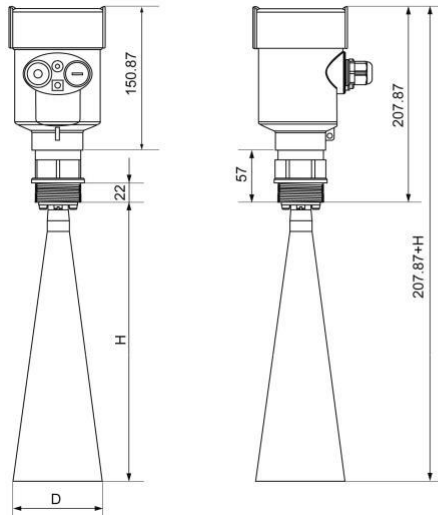

Flange	Trumpet diameter D	Trumpet height H
DN50	$\Phi 46$	140
DN80	$\Phi 76$	205
DN100	$\Phi 96$	290

## SIRD503

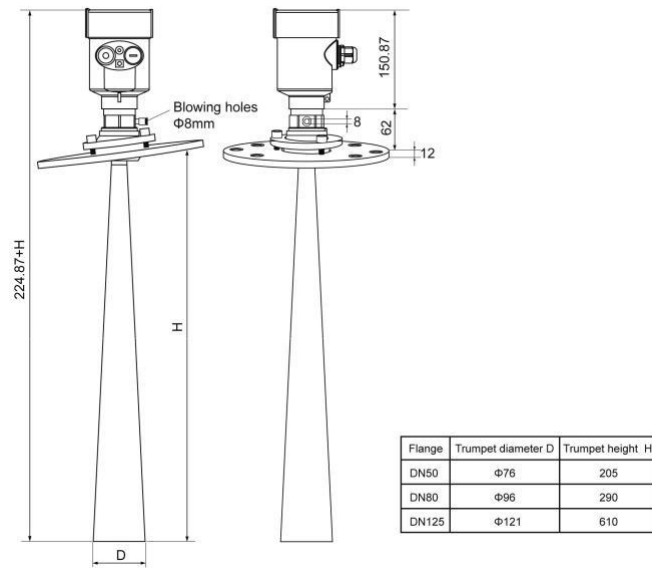

## SIRD504

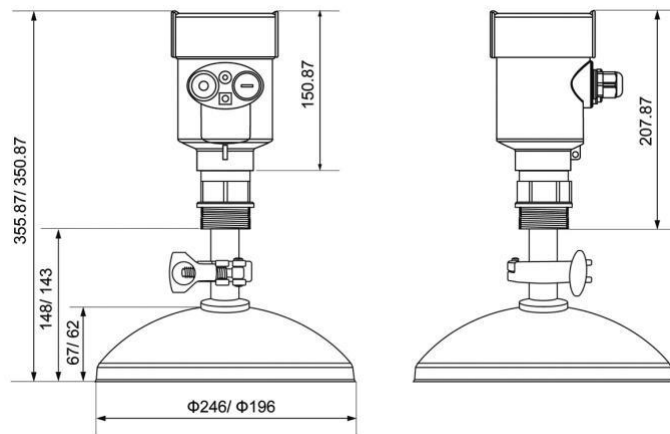

## SIRD505

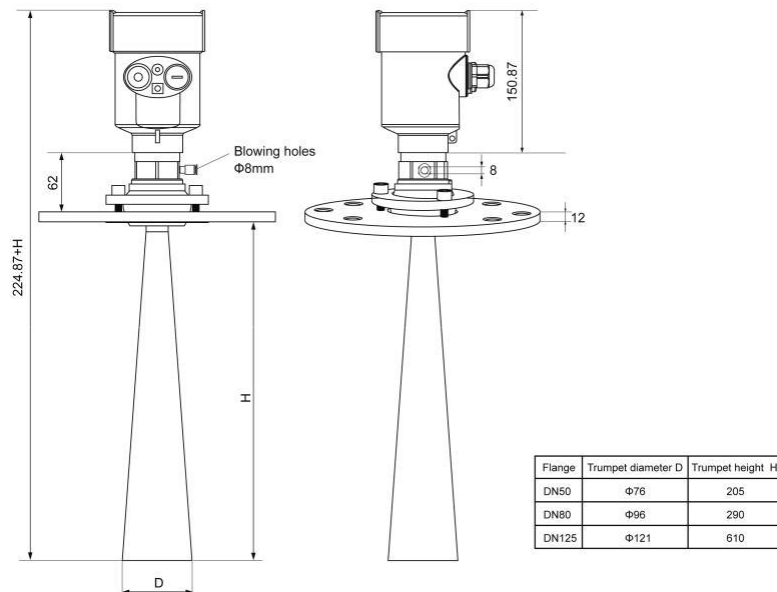

## SIRD506

Standard type

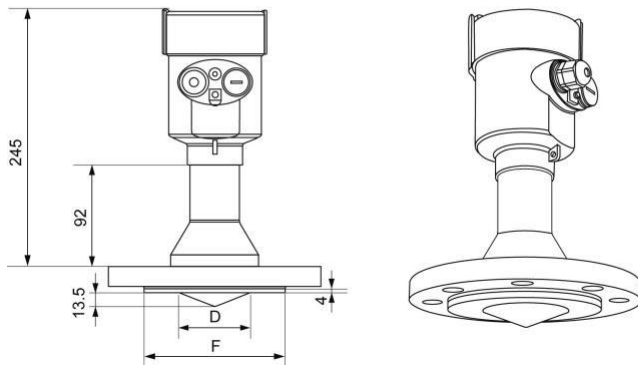

Flange	Trumpet diameter D	Sealing surface diameter F	Number of holes and hole diameter
DN50	Φ46	100	4×Φ18
DN65	Φ46	120	4×Φ18
DN80	Φ76	135	8×Φ18
DN100	Φ76	155	8×Φ18
DN125	Φ76	185	8×Φ18
DN150	Φ76	210	8×Φ23

### ● Flange type:

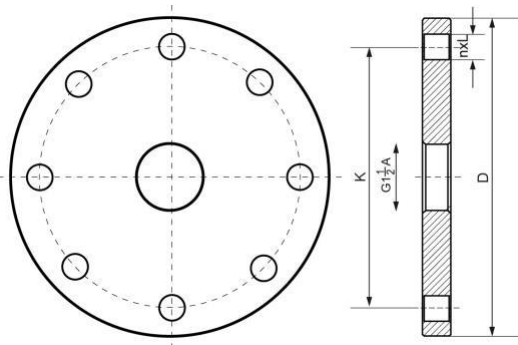

Flange Selection Tables				
Specification	Outer diameter D	Hole center distance K	Number of Holes n	Hole diameter L
DN50	Φ165	Φ125	4	18
DN80	Φ200	Φ160	8	18
DN100	Φ220	Φ180	8	18
DN125	Φ250	Φ210	8	18
DN150	Φ285	Φ240	8	22
DN200	Φ340	Φ295	12	22
DN250	Φ405	Φ355	12	26

## 7. Technical Parameters

<b>Process Connection</b>	Thread G1½" A / Thread 1½" NPT / Flange
<b>Antenna Material</b>	Stainless Steel / PTFE
<b>The outer shell</b>	
The seal between the shell and the shell cover	Silicone rubber
Casing window	Polycarbonate
The ground terminal	Stainless steel

### The power supply voltage

Two wire system

The standard type	(16 ~ 26) V DC
Intrinsically safe	(21.6 ~ 26.4) V DC
Power dissipation	max 22.5mA / 1W
Allowable ripple	
- <100Hz	U <sub>ss</sub> <IV
- (100~100K) Hz	U <sub>ss</sub> <10mV

Flameproof

(22.8 ~ 26.4) V DC	2-wire system
(198 ~242)V AC	4-wire system / 110V AC 4-wire system

## The cable parameters

Cable entrance / plug	1 M20xl.5 cable entrance 1 blind plug
Terminal	Conductor cross section 2.5mm <sup>2</sup>

## Output parameters

The output signal	(4 ~ 20) mA/RS485
Communication protocol	HART
Resolution	1.6μA
Fault signal	Constant current output; 20. 5mA 22mA 3.9mA
The integral time	(0 ~ 36) s, adjustable

**Blind area** the ends of the antenna

## The maximum distance measurement

SIRD501	10 meters	(Liquid type)
SIRD502	30 meters	(Liquid type)
SIRD502T	20 meters	(Liquid type)
SIRD503	70 meters	(Solid type)
SIRD504	80 meters	(Solid type)
SIRD505	30 meters	(Solid type)
SIRD506	20 meters	(Liquid type)

**Microwave frequency** 26GHz

**Communication interface** HART communication protocol

**The measurement interval** about 1 second (depending on the parameter settings)

**Adjust the time** about 1 second (depending on the parameter settings)

**Display resolution** 1 mm

**Working storage and transportation temperature** (-40~80)°C

**Process temperature** (the temperature of the antenna part)

SIRD501 (-40~130)°C

SIRD502 SIRD502T SIRD503 SIRD504 SIRD505 (-40~130)°C Standard type / (-40~230)°C High temperature type

SIRD506 (-40~100)°C

**Pressure** Max.4MPa

**Seismic** Mechanical vibration 10m/s<sup>2</sup>, (10 ~ 150) Hz

## 8. Meter Linearity

### SIRD501

Emission angle 20°

Precision See chart

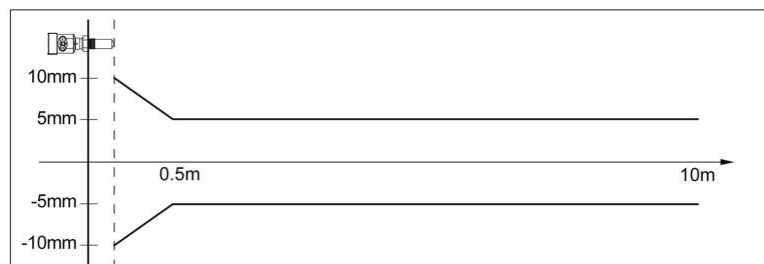



## SIRD502

Emission angle	Depending on the size of the antenna
- $\varnothing$ 46mm	18°
- $\varnothing$ 76mm	12°
- $\varnothing$ 96mm	8°
- $\varnothing$ 121mm	6°
Precision	See chart

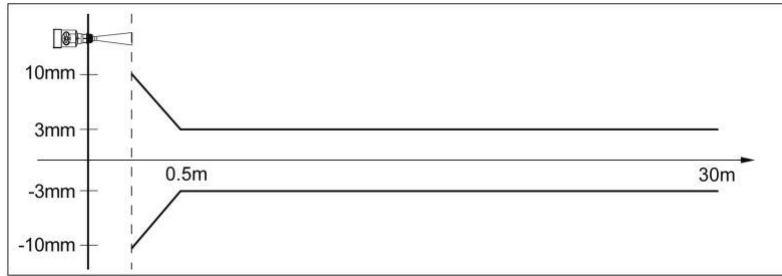

## SIRD502T

Emission angle	Depending on the size of the antenna
- $\varnothing$ 76mm	14°
Precision	See chart

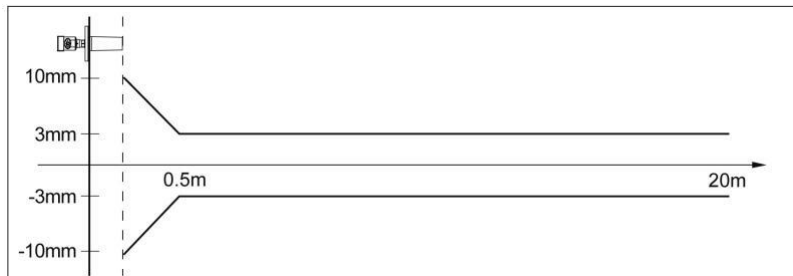

## SIRD503

Emission angle	Depending on the size of the antenna
- $\varnothing$ 46mm	18°
- $\varnothing$ 76mm	12°
- $\varnothing$ 96mm	8°
- $\varnothing$ 121mm	6°
Precision	See chart

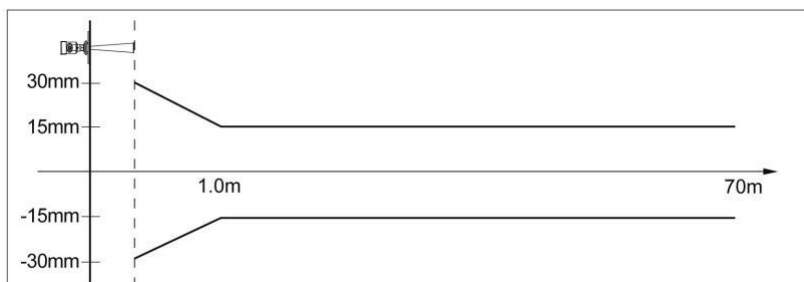

## SIRD504

Emission angle

Depending on the size of the antenna

- $\phi$  196mm

4°

- $\phi$  242mm

4°

Precision

See chart

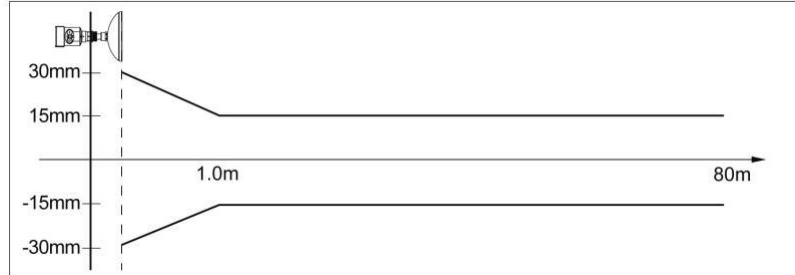

## SIRD505

Emission angle

Depending on the size of the antenna

- $\phi$  76mm

12°

- $\phi$  96mm

8°

- $\phi$  121mm

6°

Precision

See chart

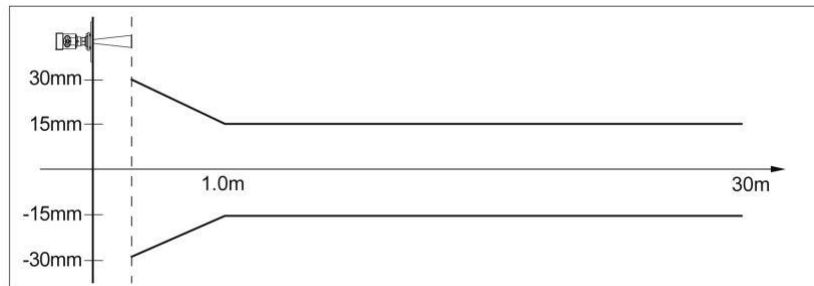

## SIRD506

Emission angle

Depending on the size of the antenna

- $\phi$  76mm

12°

Precision

See chart

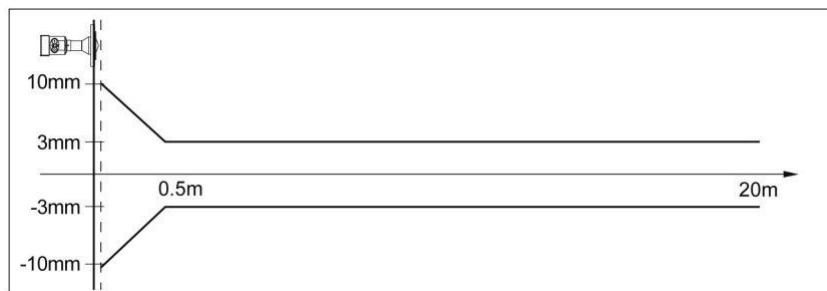

## 9. Product Model Selection

- SIRD501

### License

- P Standard (Non-explosion-proof)
- I Intrinsically safe (Exia IIC T6 Ga)
- G Flameproof (Exd IIC T6 Gb)

### Antenna Type / Material / Temperature

F Sealing horn / PTEE / -40... 130 °C

### Process Connection / Material

- G Thread G1½" A
- N Thread 1½" NPT A
- Flange DN50 /PP B
- Flange DN80 /PP C
- Flange DN100 /PP Y
- Special custom

### The Outlet Pipe Length of the Container

- A Outlet pipe 100mm
- B Outlet pipe 200mm

### The Electronic Unit

- 3 (4~20) mA / 24V DC / HART two wire system
- 4 (4~20) mA / 220V AC / HART four wire system
- 5 RS485 Modbus / 6~24V/ Four wire system

### Outer Covering / Protection Grade L

- Aluminum / Single chamber / IP67 H
- Aluminum / Double chamber / IP67 G
- Plastic / Single chamber / IP65
- K Stainless steel / Single chamber / IP67

### Cable Line

- M M 20x1.5
- N ½" NPT

### Field Display/The Programmer

- A With
- X Without

- SIRD502

### License

- P Standard (Non-explosion-proof)
- I Intrinsically safe (Exia IIC T6 Ga)
- G Flameproof (Exd IIC T6 Gb)

### Process Connection / Material

- G Thread G1½"A / Stainless Steel 304 N
- Thread 1½" NPT / Stainless Steel 304 A
- Flange DN50 / Stainless Steel 304
- B Flange DN80 / Stainless Steel 304 C
- Flange DN100 / Stainless Steel 304 Y
- Special Custom

### Antenna Type / Material

- A Horn Antenna Φ46mm / Stainless Steel 316L
- B Horn Antenna Φ76mm / Stainless Steel 316L
- C Horn Antenna Φ96mm / Stainless Steel 316L
- Y Special Custom

### Seal Up / Process Temperature

- V Viton / (-40~130) °C K
- Kalrez / (-40~230) °C

### The Electronic Unit

- 3 (4~20) mA / 24V DC / HART two wire system
- 4 (4~20) mA / 220V AC / HART four wire system
- 5 RS485 Modbus / 6~24V/ Four wire system

### Outer Covering / Protection Grade

- L Aluminum / Single chamber / IP67 H
- Aluminum / Double chamber / IP67 G
- Plastic / Single chamber / IP65
- K Stainless steel / Single chamber / IP67

### Cable Line

- M M 20x1.5
- N ½" NPT

### Field Display /The Programmer

- A With
- X Without

- SIRD502T

## License

- P Standard (Non-explosion-proof)
- I Intrinsically safe (Exia IIC T6 Ga)
- G Flameproof Type (Exd IIC T6 Gb)

## Process Connection / Material

- A Flange DN80 / Stainless Steel 304 B
- Flange DN100 / Stainless Steel 304 C
- Flange DN150 / Stainless Steel 304 Y
- Special Custom

## Antenna Type / Material

- A Internal tapered rod antenna PVDF / 78mm
- B Internal tapered rod antenna PFA / 78mm
- C Internal tapered rod antenna PVDF / 1468mm

## Seal Up / Process Temperature

- V Viton / (-40~130) °C
- P PFA / (-40~230) °C

## The Electronic Unit

- 3 (4~20) mA / 24V DC / HART 2-wire system
- 4 (4~20) mA / 220V AC / HART 4-wire system
- 5 RS485 Modbus / 6~24V / Four wire system

## Outer Covering / Protection Grade L

- Aluminum / Single chamber / IP67 H
- Aluminum / Double chamber / IP67 G
- Plastic / Single chamber / IP65
- K Stainless steel / Single chamber / IP67

## Cable Line

- M M 20x1.5
- N ½" NPT

## Field Display/The Programmer

- A With
- X Without

- SIRD503

### License

P Standard (Non-explosion-proof)  
 I Intrinsically safe (Exia IIC T6 Ga)  
 G Flameproof (Exd IIC T6 Gb)

### Process Connection / Material

G Thread G1½"A / Stainless Steel 304 N  
 Thread 1½" NPT / Stainless Steel 304 B  
 Flange DN80 / Stainless Steel 304 C  
 Flange DN100 / Stainless Steel 304 D  
 Flange DN125 / Stainless Steel 304 E  
 Flange DN150 / Stainless Steel 304 M  
 Flange DN80 / Universal joint  
 K Flange DN100 / Universal joint  
 T Flange DN125 / Universal joint  
 Z Flange DN150 / Universal joint  
 Y Special Custom

### Antenna Type / Material

B Horn Antenna Φ76mm / Stainless Steel 316L (With blow holes or dust cover) C  
 Horn Antenna Φ96mm / Stainless Steel 316L (With blow holes or dust cover) D  
 Horn Antenna Φ121mm / Stainless Steel 316L(With blow holes or dust cover)  
 Y Special Custom

### Seal Up / Process Temperature

V Viton / (-40~130) °C  
 K Kalrez / (-40~230) °C

### The Electronic Unit

3 (4~20) mA / 24V DC / HART two wire system  
 4 (4~20) mA / 220V AC / HART four wire system  
 5 RS485 Modbus / 6~24V/ Four wire system

### Outer Covering / Protection Grade

L Aluminum / Single chamber / IP67 H  
 Aluminum / Double chamber / IP67 G  
 Plastic / Single chamber / IP65  
 K Stainless steel / Single chamber / IP67

### Cable Line

M M 20x1.5  
 N ½" NPT

### Field Display/The Programmer

A With  
 X Without

- SIRD504

**License**

- P Standard (Non-explosion-proof)
- I Intrinsically safe (Exia IIC T6 Ga)
- G Flameproof (Exd IIC T6 Gb)

**Process Connection / Material**

- G Thread G1½"A / Stainless Steel 304 N
- Thread 1½" NPT / Stainless Steel 304 B
- Flange DN80 / Stainless Steel 304 C
- Flange DN100 / Stainless Steel 304 D
- Flange DN125 / Stainless Steel 304 E
- Flange DN150 / Stainless Steel 304 F
- Flange DN200 / Stainless Steel 304 H
- Flange DN250 / Stainless Steel 304 M
- Flange DN80 / Universal joint
- K Flange DN100 / Universal joint
- T Flange DN125 / Universal joint
- Z Flange DN150 / Universal joint
- W Flange DN200 / Universal joint
- V Flange DN250 / Universal joint
- Y Special Custom

**Antenna Type / Material**

- B Parabolic antenna Φ196mm / Stainless Steel 316L
- C Parabolic antenna Φ242mm / Stainless Steel 316L

**Seal Up / Process Temperature**

- V Viton / (-40~130) °C K
- Kalrez / (-40~230) °C

**The Electronic Unit**

- 3 (4~20) mA / 24V DC / HART two wire system
- 4 (4~20) mA / 220V AC / HART four wire system
- 5 RS485 Modbus / 6~24V/ Four wire system

**Outer Covering / Protection Grade**

- L Aluminum / Single chamber / IP67 H
- Aluminum / Double chamber / IP67 G
- Plastic / Single chamber / IP65
- K Stainless steel / Single chamber / IP67

**Cable Line**

- M M 20x1.5
- N ½" NPT

**Field Display/The Programmer**

- A With
- X Without

- **SIRD505**

**License**

- P Standard (Non-explosion-proof)
- I Intrinsically safe (Exia IIC T6 Ga)
- G Flameproof (Exd IIC T6 Gb)

**Process Connection / Material**

- G Thread G1½"A / Stainless Steel 304 N
- Thread 1½" NPT / Stainless Steel 304 B
- Flange DN80 / Stainless Steel 304 C
- Flange DN100 / Stainless Steel 304 D
- Flange DN125 / Stainless Steel 304 E
- Flange DN150 / Stainless Steel 304 M
- Flange DN80 / Universal joint
- K Flange DN100 / Universal joint T
- Flange DN125 / Universal joint Z
- Flange DN150 / Universal joint Y
- Special Custom

**Antenna Type / Material**

- B Horn Antenna Φ76mm / Stainless Steel 316L (With blow holes or dust cover) C
- Horn Antenna Φ96mm / Stainless Steel 316L (With blow holes or dust cover) D
- Horn Antenna Φ121mm / Stainless Steel 316L(With blow holes or dust cover)
- Y Special Custom

**Seal Up / Process Temperature**

- V Viton / (-40~130) °C
- K Kalrez / (-40~230) °C

**The Electronic Unit**

- 3 (4~20) mA / 24V DC / HART two wire system
- 4 (4~20) mA / 220V AC / HART four wire system
- 5 RS485 Modbus / 6~24V/ Four wire system

**Outer Covering / Protection Grade**

- L Aluminum / Single chamber / IP67 H
- Aluminum / Double chamber / IP67 G
- Plastic / Single chamber / IP65
- K Stainless steel / Single chamber / IP67

**Cable Line**

- M M 20x1.5
- N ½" NPT

**Field Display/The Programmer**

- A With
- X Without



- SIRD506

## License

- P Standard (Non-explosion-proof)
- I Intrinsically safe (Exia IIC T6 Ga)
- G Flameproof (Exd IIC T6 Gb)

## Process Connection /

- Material** B Flange DN80 / PTFE
- C Flange DN100 / PTFE
- D Flange DN150 / PTFE
- E Flange DN80 / Stainless Steel 304 F
- Flange DN100 / Stainless Steel 304
- G Flange DN150 / Stainless Steel
- 304 Y Special Custom

## Seal Up / Process Temperature

- V Viton / (-40~100) °C

## The Electronic Unit

- 3 (4~20) mA / 24V DC / HART two wire system
- 4 (4~20) mA / 220V AC / HART four wire system
- 5 RS485 Modbus / 6~24V/ Four wire system

## Outer Covering / Protection Grade L

- Aluminum / Single chamber / IP67 H
- Aluminum / Double chamber / IP67 G
- Plastic / Single chamber / IP65
- K Stainless steel / Single chamber / IP67

## Cable Line

- M M 20x1.5
- N ½" NPT

## Field Display/The Programmer

- A With
- X Without